



STYLE NO.

FA5575 – IVORY/GOLD

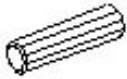
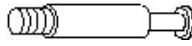
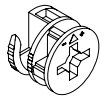
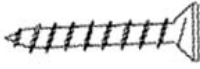
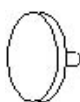
FA5596 – DISTRESSED BLACK/GOLD




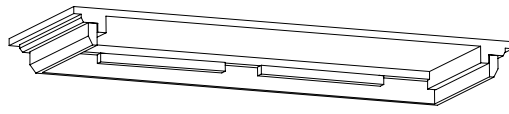
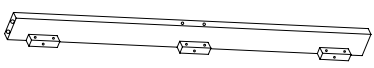

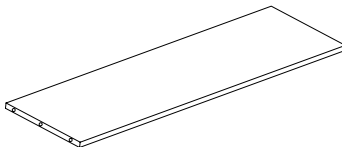
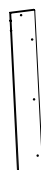
**SOUTHERN ENTERPRISES INC.**

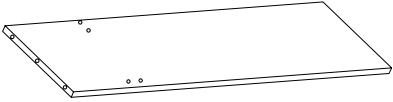
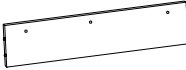



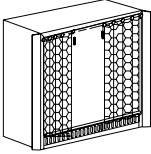
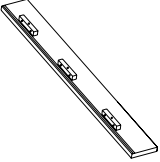
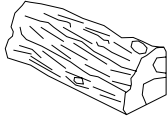
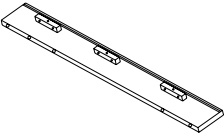
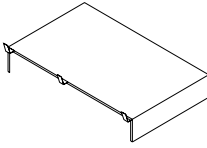
**“TAYLOR” FIREPLACE**

RELAX...If you can follow a few easy, step-by-step directions in order .YOU CAN ASSEMBLE THIS ITEM.

**PLEASE FIND HARDWARE IN RED POLYBAG BEFORE DISCARDING PACKING MATERIAL.**

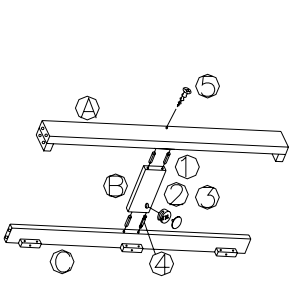
HARDWARE LIST			
(1) WOOD DOWEL	33PCS	(4) CAM-BOLT	7PCS
			
(2) CAM-LOCK	7PCS	(5) WOOD SCREW	45PCS
		 Ø8X25mm	
(3) COVER	7PCS		
			

PARTS LIST			
(A) BACK RAIL	1PC	(J) BASE	1PC
			
(B) WOOD CONNECTOR	1PC	(K) TOP PANEL	1PC
			
(C) FRONT RAIL	1PC	(L) RIGHT BACK PANEL	1PC
			
(D) RIGHT SIDE PANEL	1PC	(M) LEFT BACK PANEL	1PC
			

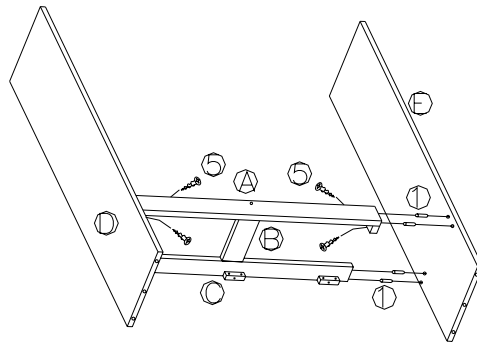
(E) LEFT SIDE PANEL 	1PC	(N) MIDDLE BACK PANEL 	1PC
(F) LOWER FRONT PANEL 	1PC	(O) WOOD HOLDER 	2PCS
(G) UPPER FRONT PANEL 	1PC	(P) FIREBOX W/SCREEN KIT 	1PC
(H) RIGHT FRONT PANEL 	1PC	(Q) MANTLE LOG 	1PC
(I) LEFT FRONT PANEL 	1PC	(R) MANTLE GRATE 	1PC
<b>NOTE: THIS CARTON DOES NOT INCLUDE PARTS “P”, “Q” AND “R”.</b>			

### ASSEMBLY INSTRUCTION

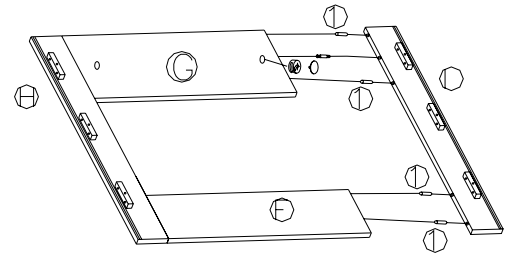
1. SELECT A SMOOTH, SOFT SURFACE TO PREVENT SCRATCHING FINISH.
2. YOU MAY NEED A PHILLIP SCREWDRIVER.
3. INSERT WOOD DOWELS (1), CAM-BOLT (4) INTO PREDRILLED HOLES ON FRONT AND BACK RAILS (C, A) AND FIT INTO CORRESPONDING HOLES ON BOTH ENDS OF WOOD CONNECTOR (B). INSERT CAM-LOCK (2) INTO BIG HOLE ON WOOD CONNECTOR (B) WITH SLOT FOR SCREWDRIVER FACING OUTWARD. ROTATE CAM-LOCK (2) CLOCKWISE TO SECURE CAM-BOLT (4). PUSH COVER (3) INTO CAM-LOCK (2). TIGHTEN WOOD SCREW (5) THROUGH PREDRILLED HOLES ON BACK RAIL (A) INTO WOOD CONNECTOR (B). AS FIGURE 1 SHOWN.
4. INSERT WOOD DOWELS (1) INTO PREDRILLED HOLES ON ENDS OF FRONT AND BACK RAILS (C, A) AND FIT INTO CORRESPONDING HOLES ON INSIDE OF LEFT AND RIGHT SIDE PANELS (E, D). TIGHTEN WOOD SCREWS (5) THROUGH PREDRILLED HOLES ON END OF BACK RAIL (A) INTO CORRESPONDING HOLES ON LEFT AND RIGHT SIDE PANELS (E, D). AS FIGURE 2 SHOWN.
5. INSERT WOOD DOWELS (1), CAM-BOLTS (4) INTO PREDRILLED HOLES ON EDGES OF LEFT AND RIGHT FRONT PANELS (I, H) AND FIT INTO CORRESPONDING HOLES ON ENDS OF UPPER AND LOWER FRONT PANELS (G, F). INSERT CAM-LOCKS (2) INTO BIG HOLES ON BACK OF UPPER FRONT PANEL (G) WITH SLOT FOR SCREWDRIVER FACING OUTWARD. ROTATE CAM-LOCKS (2) CLOCKWISE TO SECURE CAM-BOLTS (4). PUSH COVERS (3) INTO CAM-LOCKS (2). AS FIGURE 3 SHOWN.



**FIGURE 1**

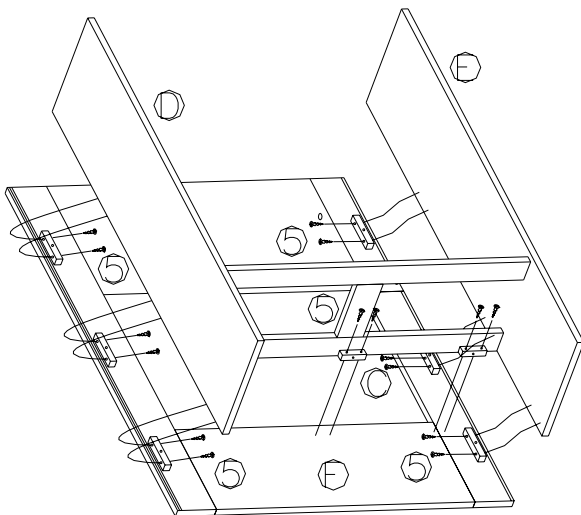


**FIGURE 2  
SHOWN BACK VIEW FOR ASSEMBLY PURPOSES**

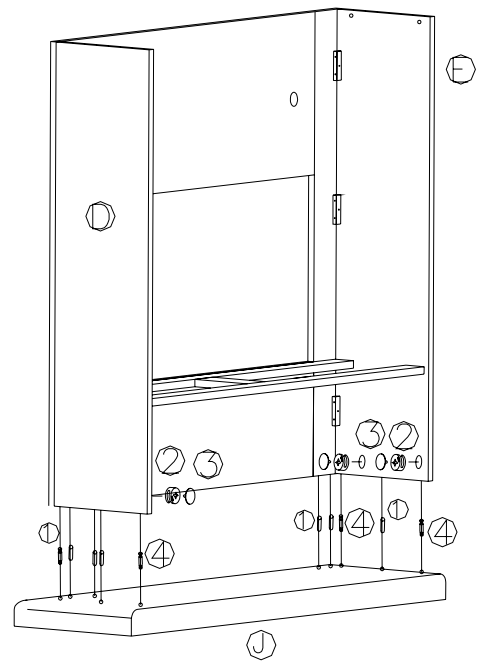


**FIGURE 3**

6. INSERT WOOD SCREWS (5) THROUGH PREDRILLED HOLES ON WOOD BARS ON PARTS (C, H, I) AND TIGHTEN INTO CORRESPONDING HOLES ON PARTS (D, E, F). AS FIGURE 4 SHOWN.
7. INSERT WOOD DOWELS (1), CAM-BOLTS (4) INTO PREDRILLED HOLES ON UPSIDE OF BASE (J) AND FIT INTO CORRESPONDING HOLES ON BOTTOM EDGES OF PARTS (D, E, H, I). INSERT CAM-LOCKS (2) INTO BIG HOLES ON INSIDE OF LEFT AND RIGHT SIDE PANELS (E, D) WITH SLOT FOR SCREWDRIVER FACING OUTWARD. ROTATE CAM-LOCKS (2) CLOCKWISE TO SECURE CAM-BOLTS (4). PUSH COVERS (3) INTO CAM-LOCKS (2). AS FIGURE 5 SHOWN.

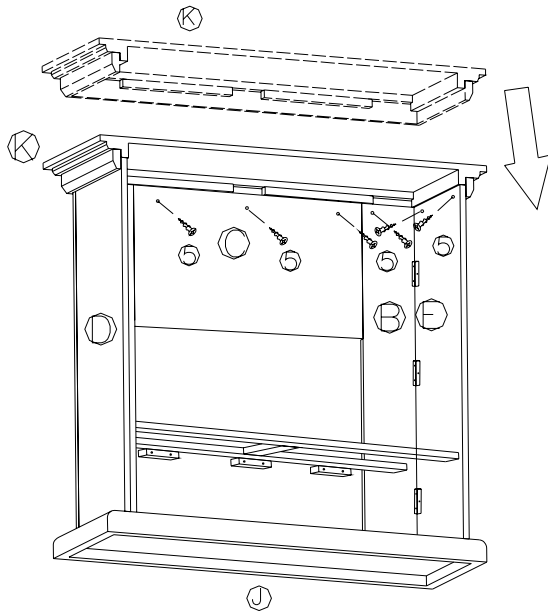


**FIGURE 4  
SHOWN BACK VIEW FOR ASSEMBLY PURPOSES**

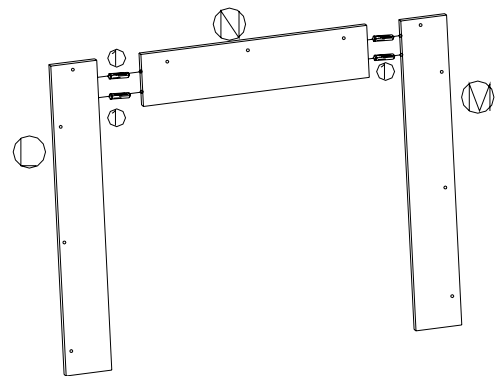


**FIGURE 5**

8. PLACE TOP PANEL (K) ON TOP EDGES OF THE ASSEMBLED ABOVE UNIT. INSERT WOOD SCREWS (5) THROUGH PREDRILLED HOLES ON PARTS (D, E, G, H, I, L) AND TIGHTEN INTO CORRESPONDING HOLES ON INSIDE OF TOP PANEL (K). AS FIGURE 6 SHOWN.
9. INSERT WOOD DOWELS (1) INTO PREDRILLED HOLES ON ENDS OF MIDDLE BACK PANEL (N) AND FIT INTO CORRESPONDING HOLES ON EDGES OF LEFT AND RIGHT BACK PANELS (M, L). AS FIGURE 7 SHOWN.

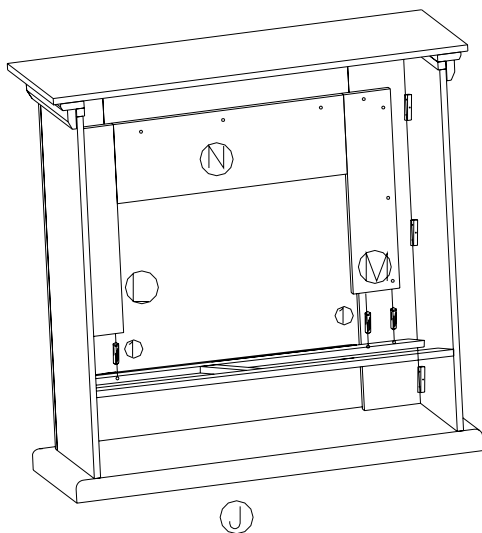


**FIGURE 6**  
**SHOWN BACK VIEW FOR ASSEMBLY PURPOSES**

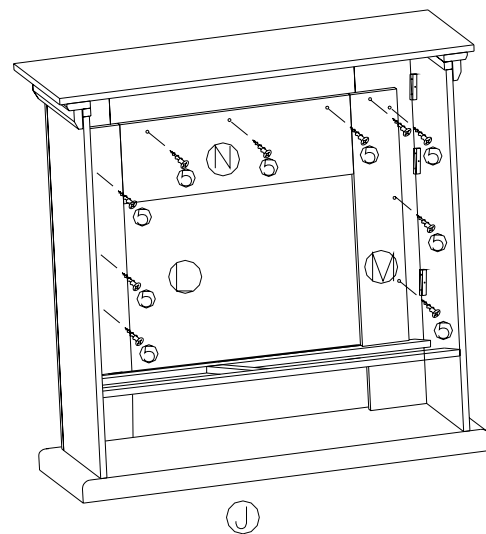


**FIGURE 7**

10. INSERT WOOD DOWELS (1) INTO BOTTOM EDGES OF LEFT AND RIGHT BACK PANELS (M, L) AND FIT INTO CORRESPONDING HOLES ON FRONT RAIL (C). AS FIGURE 8 SHOWN.
11. INSERT WOOD SCREWS (5) THROUGH PREDRILLED HOLES ON BACK PANELS (L, M, N) AND TIGHTEN INTO CORRESPONDING HOLES ON UPPER FRONT PANEL (G), LEFT AND RIGHT FRONT PANELS (I, H). AS FIGURE 9 SHOWN.



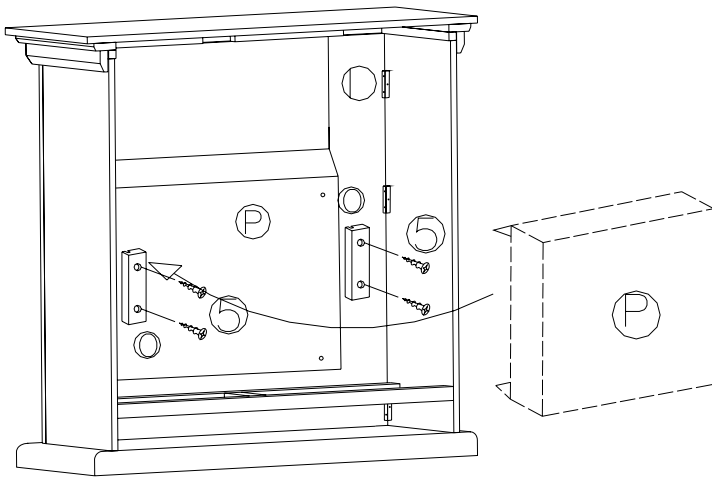
**FIGURE 8**  
**SHOWN BACK VIEW FOR ASSEMBLY PURPOSES**



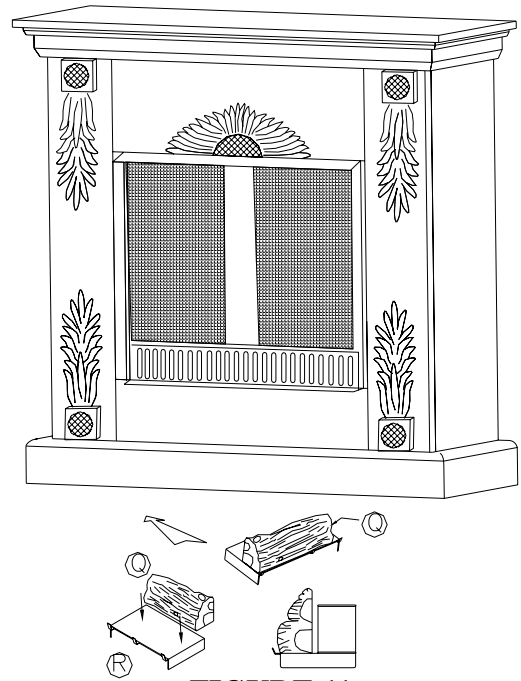
**FIGURE 9**

12. INSERT FIREBOX W/SCREEN KIT (P) FROM THE BACK OF FIREPLACE. MAKE SURE FIREBOX W/SCREEN KIT (P) IS PRESSED TIGHTLY AGAINST THE ASSEMBLED UNIT. ATTACH WOOD HOLDERS (O) ON THE SIDES OF FIREBOX W/SCREEN KIT (P). INSERT WOOD SCREWS (5) THROUGH PREDRILLED HOLES ON WOOD HOLDERS (O) AND TIGHTEN INTO CORRESPONDING HOLES ON LEFT AND RIGHT BACK PANELS (M, L). AS FIGURE 10 SHOWN.
13. PLACE MANTEL LOG (Q) UPRIGHT ON THE MANTEL GRATE (R) JUST BEHIND THE L-BRACKETS. SET MANTEL GRATE (R) IN THE FIREBOX W/SCREEN KIT (P) WITH THE L-BRACKETS FACING OUT.

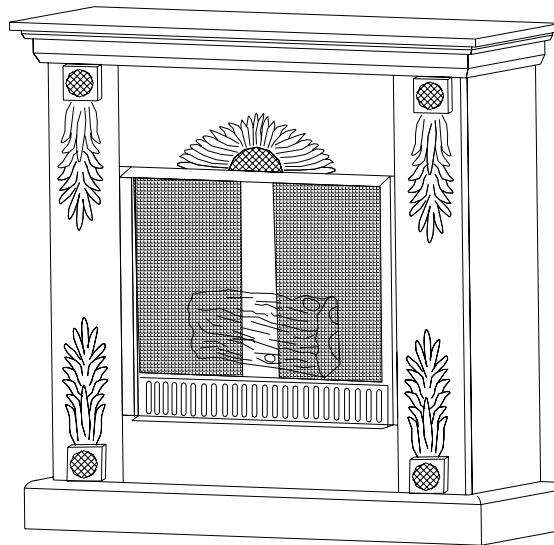
POSITION IT SO THAT IT IS CENTERED WITHIN THE FIREBOX W/SCREEN KIT (P). PLACE ONE, TWO OR THREE CANS OF FUEL (NOT INCLUDED) BEHIND THE LOG ON THE MANTEL GRATE (R). AS FIGURE 11 SHOWN.



**FIGURE 10**  
**SHOWN BACK VIEW FOR ASSEMBLY PURPOSES**



**FIGURE 11**



**READY**

**YOUR NEW "TAYLOR" FIREPLACE IS FINISHED AND READY TO USE.**


**CAUTIONS:**

- 1. REMOVE THE PAPER LABEL WHEN LIGHT THE FUEL CANS.**
- 2. DO NOT BURN MORE THAN THREE CANS OF FUEL AT ONCE.**

- 3. USE LONG MATCHES TO LIGHT THE CANS OF FUEL.**
- 4. DO NOT TOUCH THE CAN WITH BARE HANDS UNTIL THE FLAME HAS BEEN EXTINGUISHED FOR 20 MINUTES.**
- 5. DO NOT BURN ANYTHING EXCEPT THE CANS OF FUEL IN THE FIREBOX.**

Please count, identify and compare parts and hardware list to be sure all parts are present. It may help to divide parts and label them to correspond with part list. Extra hardware may be included. If any items are missing, please contact our parts/service department at (800) 633-5096 or in Dallas (972) 869-0111/ 9am – 4pm Mon-Fri Central time. Missing or damaged hardware and/ or parts will be replaced free of charge. WE DO NOT SELL PARTS. WE DO NOT RECOMMEND MODIFYING PRODUCT(S) AND WE ARE NOT RESPONSIBLE FOR ANY DAMAGES DUE TO PRODUCT MODIFICATION(S). If this product has not been purchased from our retail affiliates (within 9 months), we are under no obligation to provide parts or replacement merchandise. Parts will not be available for items arriving fully assembled.

**"We will ship parts if available" "This is not a warranty"**

<b>PARTS REPLACEMENT FORM</b>			
STYLE NO: <b>FA5575 / FA5596</b>			
Customer Name	PARTS LETTER	PART DESCRIPTION	QUANTITY NEEDED
Street, City, State, Zip			
Phone#			
		_____ _____ Please indicate where you purchased this item. Store/website/catalog _____ / _____ Please indicate color/size/style number _____ / _____	
SOUTHERN ENTERPRISES INC. P.O. Box 59996 Dallas, Texas 75229			